

Dimensions

Panel Cut-out	Hole Diameter		Max. Panel Thickness
	Min. Inches (mm)	Max. Inches (mm)	
1½" Gauge	1.625" (41.3)	1.750" (44.5)	⅛" (3.2)
2" Gauge	2.094" (53.2)	2.219" (56.4)	⅞" (11.0)
2½" Gauge	2.609" (66.3)	2.750" (69.9)	⅞" (11.0)
3½" Gauge	3.625" (92.1)	3.812" (96.8)	⅞" (11.0)

*6-32 Studs on 1½" Gauge

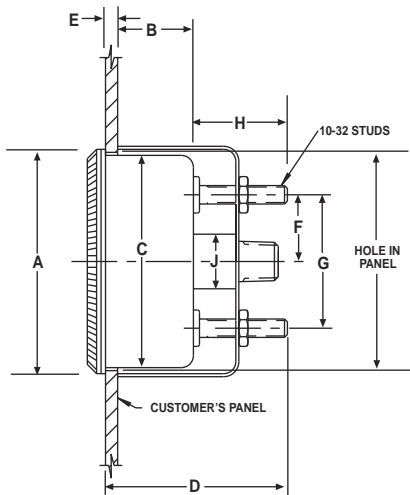

TYPE 1001T U-Clamp (UC)

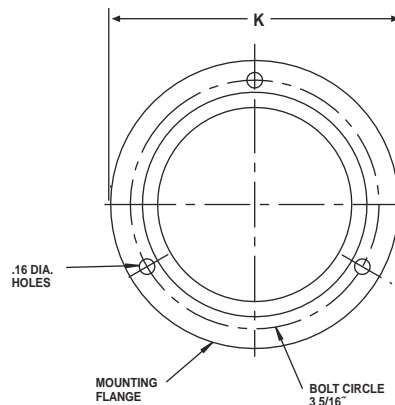

TYPE 1001T Front Flange (FF)

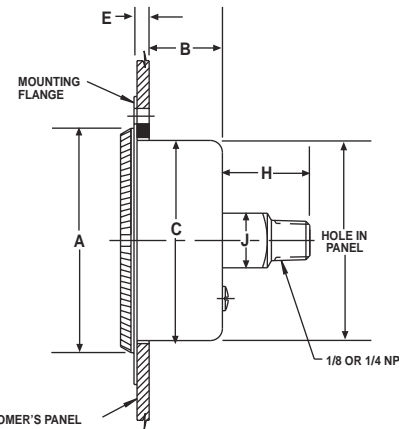

Case Type 1001T (UC)												
INCHES (MM)	A	B	C	D	E	F	G	H	J	K	L	CONN. NPT
1½"	1.85 (47)	0.85 (22)	1.60 (41)	1.23 (31)	0.13 (3)	0.56 (14)	1.13 (29)	0.67 (17)	7/16 sq. (11)	—	—	⅛ or ¼
2"	2.30 (59)	0.94 (24)	2.06 (52)	1.94 (49)	0.17 (4)	0.69 (18)	1.38 (35)	0.88 (22)	9/16 sq. (14)	—	—	⅛ or ¼
2½"	2.87 (73)	0.97 (25)	2.57 (65)	1.97 (50)	0.16 (4)	1.00 (25)	2.00 (51)	0.88 (22)	9/16 sq. (14)	—	—	⅛ or ¼
3½"	3.96 (101)	1.00 (25)	3.61 (92)	1.72 (44)	0.20 (5)	1.53 (39)	3.06 (78)	0.88 (22)	9/16 sq. (14)	—	—	⅛ or ¼
Case Type 1001T (FF)												
2"	2.30 (59)	0.88 (22)	2.06 (52)	—	0.17 (4)	—	—	0.88 (22)	9/16 sq. (14)	2.95 (75)	2.56 (65)	⅛ or ¼
2½"	2.87 (73)	0.97 (25)	2.59 (66)	—	0.17 (4)	—	—	0.86 (22)	9/16 sq. (14)	3.69 (94)	3.31 (84)	⅛ or ¼